

Microstructure and mechanical properties of NiAl produced in the SHS process induced by low-temperature hydrostatic extrusion

Z. WITCZAK*, P. WITCZAK, R. JEMIELNIAK, A. MAZUR

High Pressure Research Center, Polish Academy of Sciences, Sokolowska 29,
01-142 Warszawa, Poland

E-mail: zbigwit@unipress.waw.pl

A stoichiometric nickel aluminide intermetallic alloy produced by self-sustained high-temperature synthesis (SHS) induced to the green compacts of the mixture of elemental Ni and Al powders by mechanical heavy deformation during low-temperature hydrostatic extrusion has been investigated. The process was performed with the high strain rate ($>10^2 \text{ s}^{-1}$) at the low temperature ($\sim 500^\circ\text{C}$). To reduce the porosity, grain size and non-homogeneity of the obtained material a further high-temperature ($\sim 950^\circ\text{C}$) hydrostatic extrusion was applied. Mechanical properties of the material were measured on the samples cut out from extruded rods in the longitudinal and transverse directions. Elastic anisotropy (elastic tensor) was determined using a resonant ultrasound spectroscopy (RUS) method applied to small cylindrical samples of the material. Its value described as the ratio of the coefficients of linear compressibility in transverse and longitudinal directions was at the level of 2 for extruded material even after annealing. Plastic anisotropy of the material was determined in uniaxial compression tests using an acoustic emission (AE) method for monitoring early stages of microcracking process in the samples under investigation. The phenomenon of the yielding point was observed for the samples compressed in the direction of extrusion. © 2004 Kluwer Academic Publishers

1. Introduction

Alloys based on a nickel aluminide intermetallic compound have become valuable construction materials for high-temperature applications [1–3] due to their excellent resistance to oxidation and hot corrosion, thermal stability and high specific strength [4]. However, its very limited ductility at room temperature is still the main problem to solve. It can be partially overcome by, among others, the refinement of the microstructure of the alloy [5–7]. Recently, a self-sustained high-temperature synthesis technique has been developed for low-energy production of intermetallic alloys directly from elemental powders. This method was applied to produce intermetallics from such systems like Ni–Al [8, 9], Fe–Al [8, 10] and Ti–Ni [8]. Our work was aimed on utilising the mechanical energy that dissipates in the material during cold working process for initiation of the SHS process. We assumed that hydrostatic extrusion performed at low temperature with the high reduction ratio and high rate of deformation would be a good way to do that. Additionally, we supposed to obtain rather a fine-grained material with a small porosity due to the high-pressure conditions of the process.

2. Experimental

2.1. Production procedure

The raw materials were elemental powders of aluminium (purity $>99.5\%$) of an average size $\sim 5 \mu\text{m}$ and carbonyl nickel (purity $>99.7\%$) of an average size $\sim 3 \mu\text{m}$. The main impurity of the nickel powder was carbon ($\sim 0.2\%$). A stoichiometric composition of powders (50Ni–50Al) was mixed for 250 min in the cylindrical mixer rotated diagonally at 60 rpm. The mixture was isostatically compressed at the pressure of 270 MPa to the relative density of ~ 0.8 . The powder compacts were pumped off and sealed in the capsules made of mild steel to obtain the ingots for hydroextrusion process. The ingots were heated to the temperature of 500°C , then placed in the high pressure vessel of the hydroextrusion set-up and extruded with the reduction ratio of 4. The scheme of the hydroextrusion process is presented in Fig. 1. The temperature of the powder compact rises in the die of the hydroextrusion machine due to the high values of deformation (~ 1.3) and the high rate of deformation ($>10^2 \text{ s}^{-1}$) for about 150°C . In the same time its density rises up to nearly 1. This is the cause of the self-sustained high temperature synthesis (SHS) of elemental Al and Ni into the NiAl

*Author to whom all correspondence should be addressed.

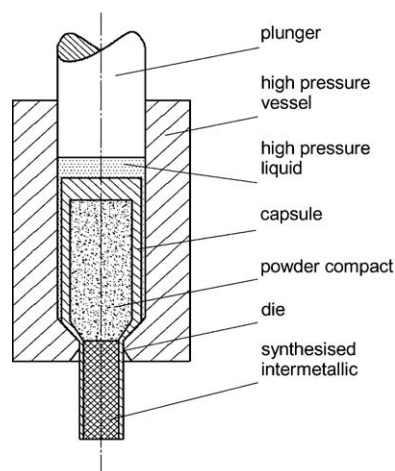

Figure 1 Schematic diagram of the hydrostatic extrusion set-up in which the SHS process is induced by low-temperature extrusion of mixed elemental powders.

intermetallic compound that is induced in the powder material during deformation. In spite of the high-pressure conditions (~ 500 MPa) the extruded rods of intermetallic were very porous in their centres. They contained numerous microcracks and needed further densification. Hence, the process of hydroextrusion was repeated for the synthesised material with the same reduction rate of 4 but at the higher temperature of $\sim 950^\circ\text{C}$. After removing the capsules the obtained rods (~ 8 mm in diameter) were spark cut into samples for farther investigations. Some part of the material was annealed (1000°C , 1 h) in order to remove the residual effects of work hardening.

2.2. Methods

The chemical effects of the SHS process was controlled with a Siemens D5000 diffractometer. The microstructure of the material was observed on the longitudinal

and transverse cross sections of extruded rods using an optical and a scanning electron microscope. The samples for mechanical tests were cylinders ($\phi 3.2 \times 5.5$ mm) or parallelepipeds ($3 \times 3 \times 5$ mm) cut out from the rod along its axis or perpendicular to it. Two or three samples were used for each measurement. Elastic properties of the material were measured using a resonant ultrasound spectroscopy (RUS) method [11–13]. The measurements were performed on cylindrical samples in the frequency range from 250 kHz to 1 MHz. Plastic properties were estimated on the basis of uniaxial compression tests at the strain rate of $\sim 10^{-3} \text{ s}^{-1}$. An acoustic emission method was used for monitoring the process of plastic deformation what allows for revealing the early stages of microcracking of the material. Both longitudinally and transversally cut out samples were investigated in order to estimate plastic anisotropy of the material.

3. Results and discussion

The X-ray observations revealed that the synthesised material is an isotropic one-phase NiAl compound which contains high residual stresses. Its microstructure is presented in Fig. 2, where some strongly work-hardened grains were abnormally etched. In the centre of extruded rod the remarkable porosity was visible. The distribution of grain sizes was wide. An average grain size was estimated for $16 \mu\text{m}$ what means that the material was a fine-grained one. In spite of the high temperature in this SHS process (that can achieve even 1800°C [9]), the fine-grained material was obtained probably due to the high rate of cooling of a melt. It could also be an explanation for high level of residual stresses.

The material obtained from hot hydrostatic extrusion was very fine-grained (Fig. 3). Its average grain size was estimated for $\sim 5 \mu\text{m}$, what had to be the result of dynamic recrystallization that took place during extrusion

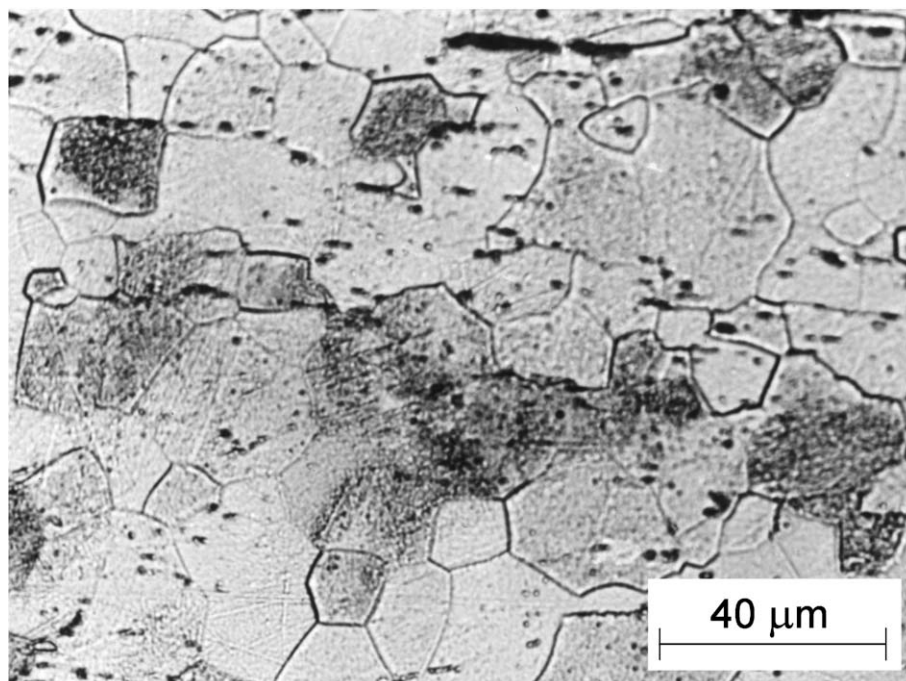

Figure 2 Microstructure of synthesised material.

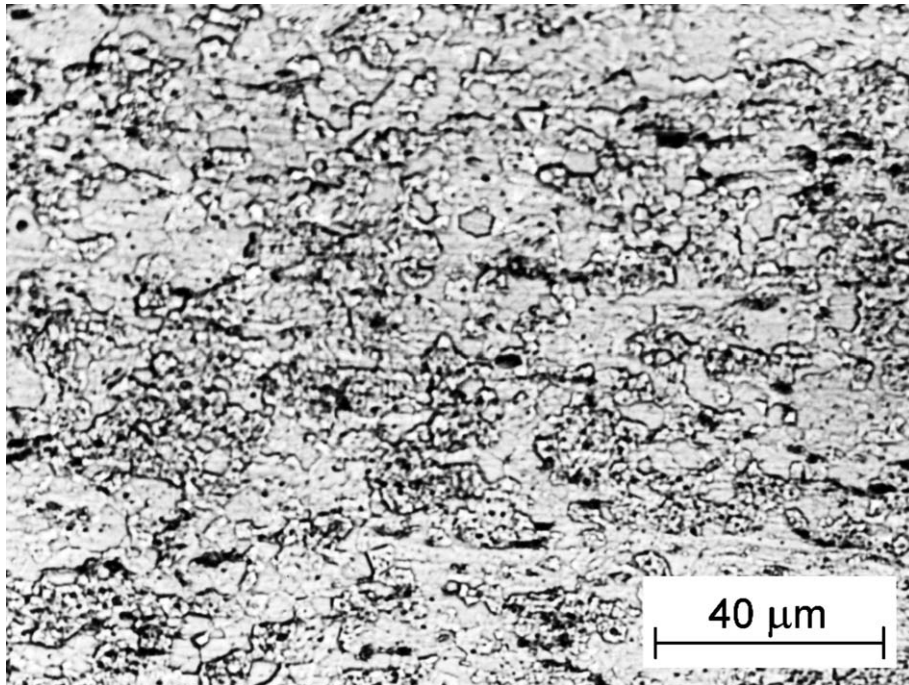

Figure 3 Microstructure of the material densified by hot hydrostatic extrusion (longitudinal section of extruded rod).

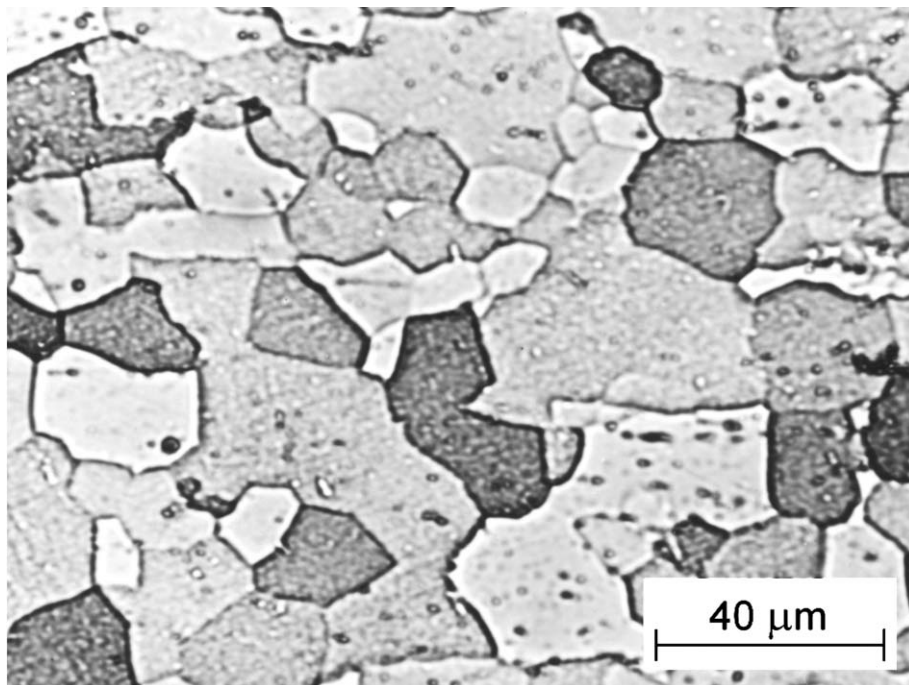

Figure 4 Microstructure of the material after annealing at 1000°C (longitudinal section of extruded rod).

under described conditions. Small porosity remained in the centre of extruded rods. After annealing for 1 h at 1000°C an average size of equiaxed grains increased to the value of $\sim 12 \mu\text{m}$ (Fig. 4). No residual stresses were noticed during X-ray observations.

It was stated on the basis of farther investigations that the extruded material had strong texture despite equiaxed shape of its grains. Mechanical anisotropy was visible not only for extruded but for annealed material as well. The extension of elastic anisotropy is shown in Fig. 5, where the spectrum of ultrasonic vibrations of a cylindrical sample of annealed material is presented. It is rather obvious that any material after

processing by extrusion should possess anisotropy of a monotropic type. The elastic constants calculated from RUS spectrum (Fig. 5) were as follows: $c_{11} = 266.5 \text{ GPa}$, $c_{12} = 42.7 \text{ GPa}$, $c_{13} = 109.9 \text{ GPa}$, $c_{33} = 294.6 \text{ GPa}$, $c_{44} = 58.3 \text{ GPa}$. To show the rate of anisotropy, the ratio of the coefficients of linear compressibility in transverse and longitudinal directions was calculated [15]. The value of ~ 2.1 was obtained which is very high taking into account the polycrystalline structure of the material. The elastic properties of equivalent isotropic material were calculated from the values of the c_{ij} tensor using the Voigt-Reuss-Hill averaging [16]. The reasonable values of the Young's modulus

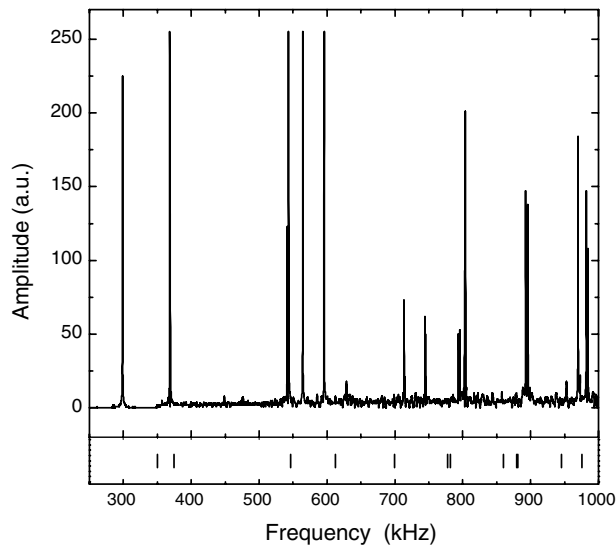

Figure 5 Resonant spectrum of ultrasonic vibrations of the cylindrical annealed sample and the spectrum of equivalent isotropic material (bars below).

(203 GPa) and Poisson's ratio (0.27) were obtained [4, 17]. These values were used for calculating the predicted RUS spectrum of equivalent isotropic material. Vibration peaks of this spectrum are presented in Fig. 5 (bottom). The discrepancy between this graph and the real spectrum is clearly seen, what is another measure of elastic anisotropy of this material.

Plastic properties of the material can be withdrawn from the true strain—true stress uniaxial compression curves presented in Fig. 6. It is seen that the plastic strength of the material ($\sigma_{0.2}$) is nearly an isotropic value. The difference between this value for the as-

extruded (~ 700 MPa) and as-annealed (~ 500 MPa) material is the obvious effect of work hardening and the Hall-Petch relationship [5, 6, 18]. This fact could be the evidence for rather the $\langle 111 \rangle$ [19, 20] than $\langle 110 \rangle$ [21] fibre texture of the material, what is the result of the high temperature of the extrusion process. The phenomenon of the yield point is visible for the longitudinal samples in spite of the fact that the material is deformed by compression, not tension. It is not quite clear, but we suppose that it can be partially the effect of the strain ageing process in deformed material [22].

Compressive deformation of intermetallic alloys is usually accompanied with the microcracking process of the material. Some part of the permanent deformation is of a cataclastic type. An acoustic emission method (AE) allows for monitoring this process [14]. The rate of AE events (first derivative of the cumulative number of AE events on time) is the measure of its intensity. It is seen that the as-extruded material is significantly more brittle (high rate of AE at the beginning of the test) in the transverse direction than in the longitudinal one (Fig. 6). This is probably also the effect of a weak texture orientation $\langle 111 \rangle$ [23] that is partially levelled during annealing.

4. Conclusions

– Self-sustained high-temperature synthesis of elemental powders of nickel and aluminium into NiAl intermetallic compound can be induced in mixed powder compacts by their low-temperature (500°C) hydrostatic extrusion.

– In spite of the high temperature (up to 1800°C) generated in this strongly exothermic SHS process, the obtained material is fine-grained ($10\text{--}20\ \mu\text{m}$ average

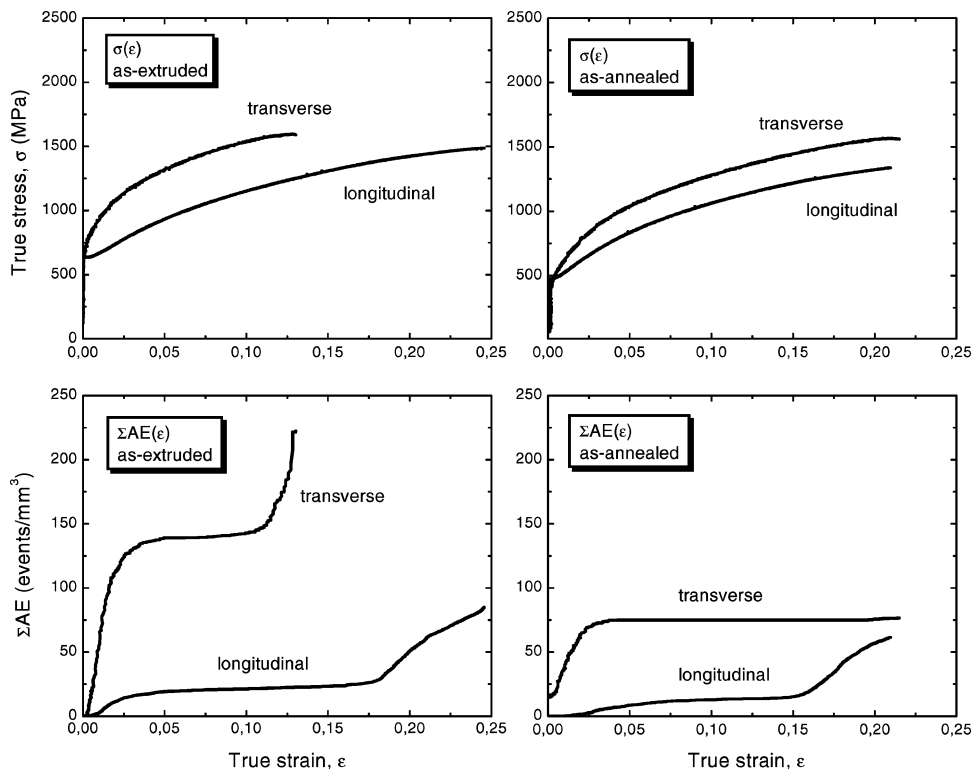

Figure 6 True stress—true strain curves obtained from uniaxial compression tests of the longitudinal and transverse samples of the material (up) and cumulative acoustic emission from tested material (down) for its as-extruded (left) and as-annealed (right) state.

grain size) although contains remarkable porosity in the centre of extruded rods.

– As a result of the subsequent high-temperature (~950°C) hydrostatic extrusion of the synthesised material its density reaches nearly its theoretical value and the refinement of the microstructure appears (down to 5–6 μm average grain size) due to the dynamic recrystallization phenomenon.

– As-extruded material shows strongly anisotropic (monotropic) elastic and plastic properties that can be only partially removed by high-temperature annealing.

Acknowledgements

We are very grateful to Ms. Ewa Grzanka for the X-ray control of produced materials. The work was sponsored by the State Committee for Scientific Research in Poland (grant No. PBZ/KBN-041/T08/07-04).

References

1. R. DARIOLA, in "Structural Intermetallics," edited by R. Dariola, J. J. Lewandowski, C. T. Liu, P. L. Martin, D. B. Miracle and M. V. Nathal (The Minerals, Metals & Materials Society, 1993) p. 495.
2. R. DARIOLA, *Intermetallics* **8** (2000) 1321.
3. F. SCHEPPE, P. R. SAHM, W. HERMANN, U. PAUL and J. PREUHS, *Mater. Sci. Eng. A* **329–331** (2002) 596.
4. D. B. MIRACLE, *Acta Metall. Mater.* **41** (1993) 649.
5. E. M. SCHULSON and D. R. BARKER, *Scripta Metall.* **17** (1983) 519.
6. P. NAGPAL and I. BAKER, *Scripta Metall. Mater.* **24** (1990) 2381.
7. I. BAKER, P. NAGPAL, F. LIU and P. R. MUNROE, *Acta Metall. Mater.* **36** (1991) 1637.
8. C.-T. HU and S. LEE, *Mater. Sci. Eng. A* **329–331** (2002) 69.
9. P. ZHU, J. C. M. LI and C. T. LIU, *ibid.* **A 329–331** (2002) 57.
10. J. RODRIGUEZ, S. O. MOUSSA, J. WALL and K. MORSI, *Scripta Mater.* **48** (2003) 707.
11. H. H. DEMARSET, *J. Acoust. Soc. Amer.* **49** (1969) 1971.
12. A. MIGLIORI, J. L. SERRAO, W. M. WISSCHER, T. M. BELL, M. LEI, Z. FISK and R. G. LEISURE, *Physica B* **183** (1993) 1.
13. R. B. SCHWARZ and J. F. VUORINEN, *J. Alloys Compd.* **310** (2000) 243.
14. Z. WITCZAK, *Mater. Sci. Eng. A* **239/240** (1997) 206.
15. J. F. NYE, "Physical Properties of Crystals" (Clarendon Press, Oxford, 1957).
16. M. W. GUINAN and D. J. STEINBERG, *J. Phys. Chem. Solids* **35** (1974) 1501.
17. N. RUSOVIC and H. WARLIMONT, *Phys. Stat. Solidi* **44** (1977) 609.
18. M. HOFFMANN and R. BIRNINGER, *Acta Mater.* **44** (1996) 2729.
19. P. S. KHADKIKAR, G. M. MICHAL and K. VEDULA, *Metall. Trans A* **21A** (1990) 279.
20. K. J. BOWMAN, J. JENNY, S. KIM and R. D. NOEBE, *Mater. Sci. Eng. A* **160** (1993) 201.
21. S. DYMEK, S. J. HWANG, M. DOLLAR and K. VEDULA, *Scripta Metall. Mater.* **273** (1992) 161.
22. M. L. WEAVER, M. J. KAUFMAN and R. D. NOEBE, *Intermetallics* **4** (1996) 121.
23. W. SKROTZKI, R. TAMM, C.-G. OERTEL, B. BECKER, H.-G. BROKMEIER and E. RYBACKI, *Mater. Sci. Eng. A* **329–331** (2002) 235.

Received 11 September 2003
and accepted 27 February 2004